

PyroBus

Non-Contact Temperature Sensor with RS485 Modbus Interface



- Wide temperature range from -20°C to 500°C
- Built-in RS485 Modbus RTU Interface
- Configurable emissivity setting and signal processing
- min; Max; average and instantaneous readings; peak or valley hold; reflected energy compensation
- 2:1, 15:1, 30:1 or close focus optics
- Fast response with high stability
- Stainless steel housing, sealed to IP65 and Quickeasy installation
- Optional air/water cooled housing, air purge collar, laser sighting tool and mounting brackets
- Optional touch screen terminals for configuration, indication, alarm generation, and data logging from multiple sensors

PYROBUS WITH MODBUS MASTER

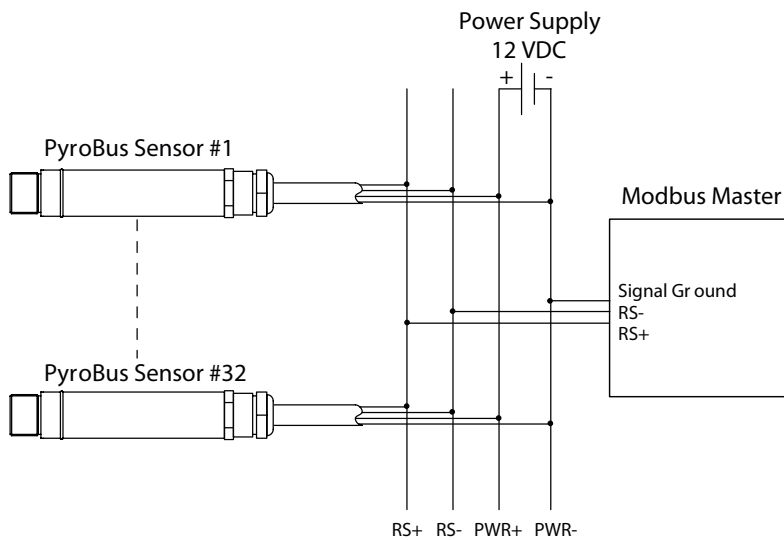

The PyroBus Series is a range of high quality, low cost, compact sensors which measure the temperature of inaccessible or moving objects and materials. They measure temperatures from -20°C to 500°C, accurately and consistently, with an outstanding response time of 240 ms.

Two-way digital communications via a built-in RS485 Modbus RTU interface enables the user to adjust the emissivity setting; compensate for reflected energy; apply filtering; select maximum, minimum, average or instantaneous readings; and peak or valley hold processing. Up to thirty two sensors can be installed on a single multidrop network.

All PyroBus sensors are fitted with precision Germanium lenses for accurate optics. Model PB21 has 2:1 optics making it suitable for most applications where the sensor can be mounted close to the target. Model PB151 is designed for small or distant targets and has an optical resolution of 15:1. Model PB301 is designed for very small or distant targets and has an optical resolution of 30:1. Model PBCF is designed for targets as small as $\varnothing 5\text{mm}$ at a distance of 100mm from the sensor.

These compact sensors are small enough to fit almost anywhere and their rugged stainless steel housings make them ideal for applications where cleanliness and hygiene are paramount.

DIAMETER OF TARGET SPOT MEASURED VERSUS DISTANCE FROM SENSING HEAD

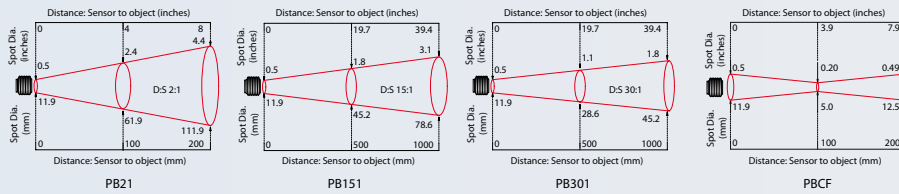

ACCESSORIES

FIXED MOUNTING BRACKET



The L-shaped fixed mounting bracket offers a rigid support for the sensor and allows fine adjustment in a single plane.

ADJUSTABLE MOUNTING BRACKETS



and allows fine adjustment in two planes.

The adjustable mounting bracket consists of a fixed mounting bracket plus another L-shaped bracket. When assembled as shown the adjustable mounting bracket offers a rigid support for the sensor

GENERAL SPECIFICATIONS

Temperature Range	-20°C to 500°C
Interface	RS485 Modbus RTU
Accuracy	±1% of reading or ±1°C whichever is greater
Repeatability	± 0.5% of reading or ± 0.5°C whichever is greater
Emissivity	0.2 to 1.0
Response Time, t_{90}	240 ms (90% response)
Spectral Range	8 to 14 μm
Supply Voltage	12 V DC nominal (6 - 13 V DC)
Supply Current	50 mA max.
Baud Rate	9600 baud *
Format	8 data bits, no parity, 1 stop bit *

MECHANICAL

Construction	Stainless Steel
Dimensions	18 mm diameter x 103 mm long
Thread Mounting	M16 x 1 mm pitch
Cable Length	1m (longer lengths available to order)
Weight with Cable	95 g

ENVIRONMENTAL

Environmental Rating	IP65
Ambient Temperature	0°C to 70°C
Relative Humidity	95%max. non-condensing

* Other configurations available upon request

AIR PURGE COLLAR



The air purge collar is used to keep dust, fumes, moisture and other contaminants away from the lens. Air flows into the fitting on the side and out of the aperture at the front.

AIR/WATER COOLED HOUSING



The air/water cooled housing allows the sensor to withstand ambient temperatures which exceed the normal 70°C limit. Air or water (depending on the degree of cooling required) flows into one of the fittings on the side and out of the other. To prevent condensation forming on the lens, the air/water cooled housing is supplied complete with an air purge collar. Please note, the air/water cooled housing must be ordered with the sensor and cannot be fitted by the user.

LASER SIGHTING TOOL



The Laser Sighting Tool screws onto the front of the sensor and indicates precisely where the sensor is aiming. Once the sensor has been aimed at the centre of the target and locked in position the Laser Sighting Tool can be removed. The laser is activated by means of a push button on the front of the tool which has a latching mechanism.

MODEL NUMBERS

