

T6 Series intelligent power controller



Features:

- Three phase power regulator, auto phase detection
- Soft start function to protect SCR and load against surge current
- Integrated display with various LED indicator for status and error display
- Integrated heatsink and fans with temperature detection
- Over temperature alarm, output protection after alarm on
- Maximum and minimum output configurable
- Auto/manual control bumpless transfer
- Run/stop function
- RS-485 modbus RTU display
- Event input function
- Rated load voltage 380~440Vac 50/60HZ
- Power supply for SCR to work is 230Vac or 12-24Vdc optional
- Input, 0-10Vdc, 4-20mA, 0-5Vdc, 1-5Vdc, 2-10Vdc, 0-20mA, 0-10mA
- Rated current options, 40 amps, 60 amps, 75 amps, 100 amps.
- This SCR only compatible with resistive load

Technical Specifications

Ordering Information

T-6-2345-67

1: Type of SCR power regulators

6 6 series SCR regulator

2: Load phase

3 3 phase load system

3: Load current

4 40 amps 380~440Vac
 6 60 amps 380~440Vac
 7 75 amps 380~440Vac
 1 100 amps 380~440Vac

3: Power supply for the unit itself

2 230Vac
 D 12-24Vdc

4: Input signal

1 0-10mA
 2 0-20mA
 8 4-20mA
 5 0-5Vdc(potentiometer)
 6 0-10Vdc
 7 1-5Vdc
 3 2-10Vdc

5: Over temperature alarm

N without alarm
 M with 1 alarm, relay output

6: Communication

N without communication
 M With RS-485 modbus RTU communication

Remarks - T6 have alarm and Rs485 options
 - T6 series available with 100 Amps

Size and dimensions



Model: T6-3428 40 Amps
 overall size:160mm*140mm*145mm
 Mounting size:120mm*130mm

Model: T6-3628 60 Amps
 overall size:160mm*140mm*145mm
 Mounting size:120mm*130mm

Model: T6-3728 75 Amps
 overall size:160mm*140mm*145mm
 Mounting size:120mm*130mm

Model: T6-3128 100 Amps
 overall size:220mm*140mm*145mm
 Mounting size:150mm*130mm

Panel description

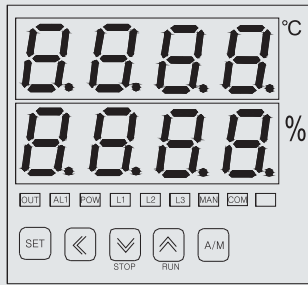

- INDICATOR**
- OUT: The flashing frequency indicate the output ratio
 - AL1: Over temperature alarm indicator
 - POW: Power feed indicator
 - L1: Phase indicator, when L1 absence, lights on
 - L2: Phase indicator, when L2 absence, lights on
 - L3: Phase indicator, when L3 absence, lights on
 - MAN: Manual control indicator
 - COM: Communication indicator
- SET KEY**
- SET: Parameter setting and configuraion
 - A/M: Manual/auto control switch
 - POW: Power feed indicator
 - <: Left shift key, to shift the display unit
 - v: Decrease key or Stop key

Connection diagram

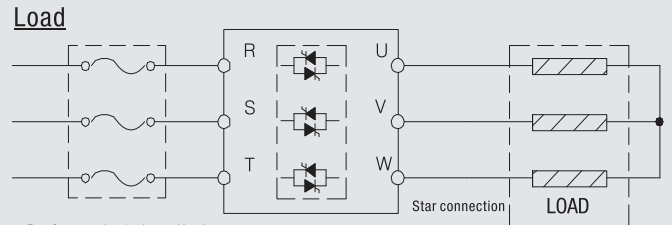

Fast fuse rated at 1.5*actual load
for example, if the acutal current is 20 amps
then fast fuse should be 30 amps

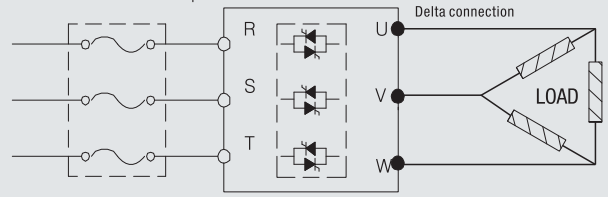

T6

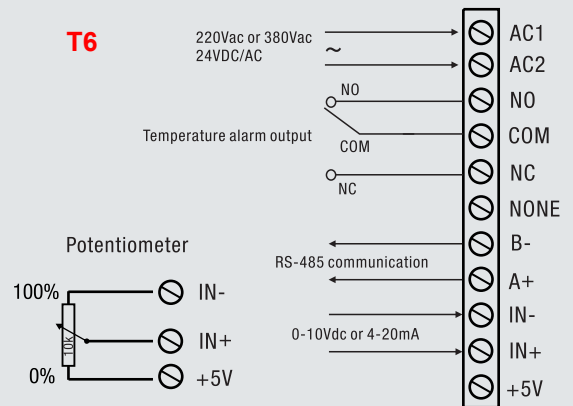

Performance

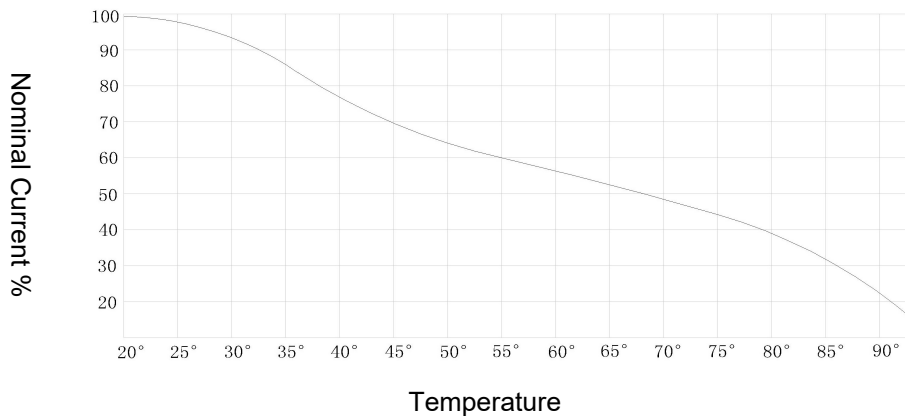

Is recommended to work up to 60% of the rated power

Power Up

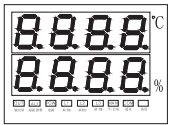

Power Up

→
1 Sec

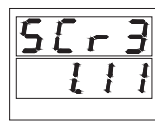

Upper : SCR3
Lower : 1.11

→
1 Sec



Normal display
Upper display shows heatsink temperature
Lower display shows the input percentage

Configuration flow chart

Menu Level 1

Press SET once to enter Menu Level 1



UAD : To display the communication address
uad=ADD (ADD was preset during the communication setup)
Press SET to password parameter

↓
Passwork "LCK"



SET LCK=101 , Press SET to goes to menu level 1
Press SET

↓
Level 1

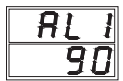

AL1
SET a temperature for alarm to be triggered if heatsink temp exceed set value, when AL1 set as "0" , this function disabled

↓
Press SET



EOP
Output value goes down to EOP value if over temperature alarm on
eg : When SCR temp reaches to AL1 alarm, the output goes down to EOP value

↓
Press SET



OPL
Minimum output parameter, Range : 0.0-100.0%
Eg : When there is no signal feed from outside, the SCR still output at OPL value

↓
Press SET



OPH
Minimum output parameter, Range : 0.0-100.0%
Eg : The maximum output can be restrained at OPH value to protect the system

↓
Press SET



BUF
Soft-start parameter , Range:0.0-100.0
The outut change ratio per second
Eg : BUF=10.0 , means that it takes 10 seconds for the SCR output changes from 0.0-100.0% BUF=100.0, soft-start function disabled

↓
Press SET

ADD: communication setting parameter

Range : 0-127

Set Communication address for each SCR

↓ Press SET

BAU

BAU: communication speed

Range : 24:2.4KBPS 48:4.8KBPS 96:9.6KBPS 192:19.2KBPS

↓ Press SET to exit

Level 2

Press SET once to enter

UAD : To display the communication address

uad=ADD (ADD was preset during the communication setup)

Press SET to password parameter

↓

Parameter LCK

Set LCK= 202 , Press SET to goes to auto/manual parameter

Press SET to enter

↓

AUTO(Auto/manual control configuration)

0 : auto/manual function off

1 : auto/manual function on

↓

Press SET

RUN(Run/stop configuration)

0 : Run/stop off

1 : Run/stop on

↓

Press SET

HZ : To choose the power supply frequency

↓

Press SET to exit

Cautions !!!

- SCR can not be operated without load or load current less than 0.5
- Please make sure to tighten the screw securely while wiring the SCR, otherwise extra heat will be accumulated on the terminals results a damage on the SCR
- SCR must be mounted vertically on a solid panel without any objects placed above or beneath the SCR to make sure a smooth air flow
- If multiple SCR installed at the same control cabinet, the main principle is to make the air flow efficient among each unit.
- The temperature inside of the control cabinet must be lower than 55 celsius, otherwise a cooling fan must be installed
- If two SCR installed paralleled, the distance between the two units must be more than 5CM
- It is user's responsibility to make sure your selection on the SCR is compatible with your application
- For safety consideration, a circuit breaker must be installed between the load and SCR.
- Touch the input and output terminals have the same risk even if there is not current at some certain period while SCR is still working
- Never ever try to replace the cooling fans when SCR is working
- Make sure the load voltage compliance with the ratings of SCR
- Always make sure the wiring goes to the correct negative and positive terminals